



SPECTRACOM
PUBLIC SAFETY) SECURITY) GOVERNMENT

MODEL 8144-RR

Clock Selector/Distribution Amplifier

Instruction Manual

SPECTRACOM CORPORATION
95 Methodist Hill Drive, Suite 500
Rochester, NY 14623

Phone 585.321.5800
Fax 585.321.5219

www.spectracomcorp.com

REVISIONS, IF ANY, ARE LOCATED AT THE END OF THE MANUAL

REVISION A
December 2003

LIMITED WARRANTY

Spectracom warrants each new product manufactured and sold by it to be free from defects in material, workmanship, and construction, except for batteries, fuses, or other material normally consumed in operation that may be contained therein, for five years after shipment to the original purchaser (which period is referred to as the "warranty period"). This warranty shall not apply if the product is used contrary to the instructions in its manual or is otherwise subjected to misuse, abnormal operations, accident, lightning or transient surge, repairs or modifications not performed by Spectracom.

The GPS receiver is warranted for one year from date of shipment and subject to the exceptions listed above. The power adaptor, if supplied, is warranted for one year from date of shipment and subject to the exceptions listed above.

The Rubidium oscillator, if supplied, is warranted for two years from date of shipment and subject to the exceptions listed above.

All other items and pieces of equipment not specified above, including the antenna unit, antenna surge suppressor and antenna pre-amplifier are warranted for 5 years, subject to the exceptions listed above.

WARRANTY CLAIMS

Spectracom's obligation under this warranty is limited to in-factory service and repair, at Spectracom's option, of the product or the component thereof, which is found to be defective. If in Spectracom's judgment the defective condition in a Spectracom product is for a cause listed above for which Spectracom is not responsible, Spectracom will make the repairs or replacement of components and charge its then current price, which buyer agrees to pay.

Spectracom shall not have any warranty obligations if the procedure for warranty claims is not followed. Users must notify Spectracom of the claim with full information as to the claimed defect. Spectracom products shall not be returned unless a return authorization number is issued by Spectracom. Spectracom products must be returned with the description of the claimed defect and identification of the individual to be contacted if additional information is needed. Spectracom products must be returned properly packed with transportation charges prepaid.

EXCEPT FOR THE LIMITED WARRANTY STATED ABOVE, SPECTRACOM DISCLAIMS ALL WARRANTIES OF ANY KIND WITH REGARD TO SPECTRACOM PRODUCTS OR OTHER MATERIALS PROVIDED BY SPECTRACOM, INCLUDING WITHOUT LIMITATION ANY IMPLIED WARRANTY OR MERCHANTABILITY OR FITNESS FOR A PARTICULAR PURPOSE.

Spectracom shall have no liability or responsibility to the original customer or any other party with respect to any liability, loss, or damage caused directly or indirectly by an Spectracom product, material, or software sold or provided by Spectracom, replacement parts or units, or services provided, including but not limited to any interruption of service, excess charges resulting from malfunctions of hardware or software, loss of business or anticipatory profits resulting from the use or operation of the Spectracom product or software, whatsoever or howsoever caused. In no event shall Spectracom be liable for any direct, indirect, special or consequential damages whether the claims are grounded in contract, tort (including negligence), or strict liability.

EXTENDED WARRANTY COVERAGE

Extended warranties can be purchased for additional periods beyond the standard five-year warranty. Contact Spectracom no later than the last year of the standard five-year warranty for extended coverage.

TABLE OF CONTENTS

SECTION 1 GENERAL INFORMATION

1.0	INTRODUCTION	1-1
1.1	FEATURES.....	1-1
1.2	WARRANTY INFORMATION AND PRODUCT SUPPORT	1-2
1.3	MANUAL ERRATA AND SPECIAL DOCUMENTATION	1-2
1.4	UNPACKING	1-2
1.5	CONFIGURATION OPTIONS.....	1-3
1.6	SPECIFICATIONS	1-3
1.6.1	Inputs	1-3
1.6.2	Outputs	1-4
1.6.3	Power Requirements	1-4
1.6.4	Mechanical and Environmental Specifications.....	1-4
1.6.5	Status Indicators	1-5
1.6.6	Operator Controls	1-5
1.6.7	User-Configurable Options	1-6
1.6.8	Alarm Outputs.....	1-6
1.6.8.1	Alarm Classification.....	1-6
1.6.8.2	Alarm Interface.....	1-7

SECTION 2 INSTALLATION

2.0	INTRODUCTION	2-1
2.1	PREPARATION FOR USE	2-1
2.1.1	AC Line Voltage Selection	2-1
2.1.2	Power Options	2-2
2.2	SWITCH AND HEADER SETTINGS	2-3

SECTION 3 OPERATION

3.0	INTRODUCTION	3-1
3.1	THEORY OF OPERATION.....	3-2
3.2	FRONT PANEL FUNCTIONS.....	3-2
3.3	REAR PANEL CONNECTIONS.....	3-4

SECTION 4 OPTIONS

4.1	DC POWER OPTIONS 52 AND 54.....	4-1
4.2	MOUNTING OPTIONS	4-1
4.2.1	Option 11, Slides	4-1
4.2.2	Option 102, 23/24-inch Rack Mount	4-2
4.2.3	Option 103, Setback Mount	4-3

SECTION 5 SERVICE INFORMATION

5.0	MAINTENANCE AND CALIBRATION	5-1
5.1	FUSE REQUIREMENTS	5-1

LIST OF TABLES

TABLE 1-1	CONFIGURATION SUMMARY	1-3
TABLE 2-1	SWITCH AND HEADER SETTINGS	2-3
TABLE 3-1	CLOCK OUTPUT CONNECTOR PINS	3-5
TABLE 4-1	OPTION 11 CHECKLIST	4-1
TABLE 4-2	OPTION 102 CHECKLIST	4-2
TABLE 4-3	OPTION 103 CHECKLIST	4-3

LIST OF ILLUSTRATIONS

FIGURE 2-1	LINE VOLTAGE SELECTION/FUSE REPLACEMENT	2-2
FIGURE 2-2	MODEL 8144-RR COMPONENT LAYOUT	2-4
FIGURE 2-3	8144-RR REAR PANEL - 115/230 VAC	2-8
FIGURE 2-4	8144-RR REAR PANEL - DC POWERED OPTION 52	2-8
FIGURE 2-5	8144-RR REAR PANEL - DC POWERED OPTION 54	2-9
FIGURE 2-6	8144-RR FRONT PANEL	2-9
FIGURE 3-1	MODEL 8144-RR BLOCK DIAGRAM.....	3-1
FIGURE 3-2	MODEL 8144-RR FRONT PANEL.....	3-3
FIGURE 3-3	MODEL 8144-RR REAR PANEL - 115/230 VAC.....	3-4

SECTION 1 GENERAL INFORMATION

1.0 INTRODUCTION

1.1 FEATURES

1.2 WARRANTY INFORMATION AND PRODUCT SUPPORT

1.3 MANUAL ERRATA AND SPECIAL DOCUMENTATION

1.4 UNPACKING

1.5 CONFIGURATION OPTIONS

1.6 SPECIFICATIONS

GENERAL INFORMATION

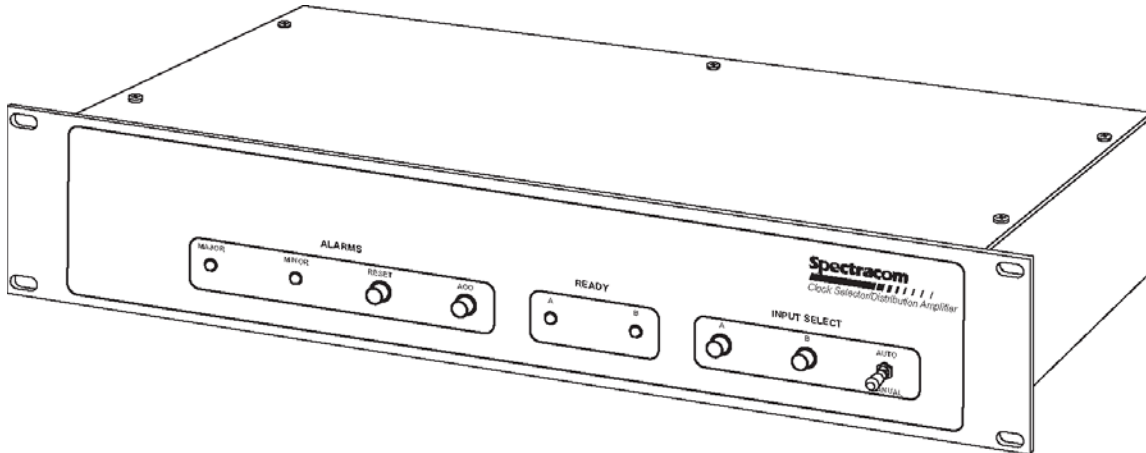

1.0 INTRODUCTION

The 8144-RR Clock Selector/Distribution Amplifier enhances reliability by providing manual or automatic switchover to a backup system clock when the primary system clock has failed. The 8144-RR also provides twelve outputs for distribution of the selected clock.

1.1 FEATURES

The 8144-RR Clock Selector/Distribution Amplifier offers the following features:

- Manual or automatic switchover between two clock sources or single input operation.
- Local and remote alarm indicators, normal or latched, reset from the front panel.
- Redundant power sources
- Twelve independent outputs.
- RS-422/485 input and output signals.

1.2 *WARRANTY INFORMATION AND PRODUCT SUPPORT*

Warranty information is found on the leading pages of this manual. Contact Spectracom Corporation to obtain a replacement or service.

Spectracom continuously strives to improve its products. We greatly appreciate any and all customer feedback given. Please direct any comments or questions regarding application, operation, or service to Spectracom's Customer Service Department. Customer Service is available Monday through Friday from 8:30 A.M. to 5:00 P.M. Eastern time at **585-321-5800**.

Before returning any instrument to Spectracom Corporation, please contact Customer Service to obtain a Return Material Authorization Number (RMA#). Please provide the serial number and failure symptoms. Transportation to the factory is to be prepaid by the customer.

1.3 *MANUAL ERRATA AND SPECIAL DOCUMENTATION*

Information concerning manual corrections or changes made to the instrument occurring after the printing of this manual are found on the errata sheet located at the rear of this manual.

Spectracom sometimes makes instrument modifications upon special request. The documentation associated with any special modifications is also located in the back of the manual.

1.4 *UNPACKING*

Upon receipt, examine the carton and its contents carefully. If there is carton damage which results in damage to the unit, contact the carrier immediately so its representative may witness such damage. If you fail to report shipping damage immediately, you may forfeit any claim against the carrier. You should also notify Spectracom Corporation of shipping damage or shortages so that we can either help you obtain a replacement or repair the damaged equipment.

Open the shipping carton carefully and remove the packing list from the envelope on the outside of the carton. Check the packing list against the contents to be sure all items have been received, including an Instruction Manual and an ancillary kit.

Retain the carton and packing materials in the event the unit is reshipped or returned to the factory.

1.5 CONFIGURATION OPTIONS

The Model 8144-RR Clock Selector/Distribution Amplifier can be ordered in a variety of power, and mounting configurations. When specific configurations are referenced in this Instruction Manual, the format 8144-RR-P-M is used, where P and M are the power, and mounting option designations, respectively. These options are listed below in Table 1-1, Configuration Summary.

Option Type	Option	Designation
Power (P)	AC (Standard) 12 to 24 VDC Power 48 VDC Power	(none) 52 54
Mounting (M)	19" Rack (Standard) 19" Rack with Slides 23/24" Rack 19" Setback Rack	(none) 11 102 103

TABLE 1-1 CONFIGURATION SUMMARY

1.6 SPECIFICATIONS

1.6.1 Inputs

The Model 8144-RR accepts one or two clock inputs in the format listed below, as well as one or two alarm inputs.

RS-422/485 CLOCK INPUTS:

The RS-422/485 clock inputs comply with the EIA Standards for RS-422A and RS-485 as follows:

Line Rate:	Internal jumper enables operation from 4 kHz to 2.048 MHz.
Tolerance:	Not specified
Level:	Sensitivity ± 200 mV, hysteresis 50 mV typical
Termination:	Balanced twisted pair
Impedance:	Terminated: 120 ohms $\pm 5\%$ Unterminated: 12K ohms minimum

ALARM INPUTS:

The alarm inputs are configured to operate as RS-422/485 receivers as follows:

Line Rate:	DC
Level:	Sensitivity ± 200 mV, hysteresis 50 mV typical
Termination:	Balanced twisted pair
Impedance:	Terminated 120 ohms $\pm 5\%$ Unterminated $> 4K$ ohms

Alarm inputs can also be configured for contact closure input. A contact closure between pins 1 and 3 on the alarm inputs alarms the A channel. A contact closure between pins 4 and 6 alarms the B channel.

1.6.2 Outputs

The Model 8144-RR provides up to twelve clock outputs.

RS-422/485 CLOCK OUTPUTS:

The twelve RS-422/485 clock outputs comply with the EIA standard for RS-422A and RS-485 outputs as follows:

Line Rate:	4 kHz through 2.048 MHz (determined by clock input)
Tolerance:	Not specified
Level:	Differential output voltage between the two output terminals. 1.5 to 5.0V into a 54-ohm load for either binary state.
Termination:	Balanced twisted pair
Impedance:	To match 60-ohm load

1.6.3 Power Requirements

Standard Option:	115/230 VAC $\pm 15\%$ 50/60 Hz, 15 watts
Option 52, 12 to 24 VDC:	± 11.0 to 32.0 VDC, 12 watts
Option 54, 48 VDC:	± 55.2 VDC $\pm 20\%$, 12 watts

1.6.4 Mechanical and Environmental Specifications

Height:	2 rack units (3.50 inches)
Width:	EIA 19" rack
Depth:	10 inches
Weight:	6 lbs. maximum
Temperature:	0 to $+60^{\circ}\text{C}$ operating range
Humidity:	95% R. H. non-condensing

1.6.5 Status Indicators

The red MAJOR ALARM lamp is on when both references have been lost or both alarm inputs are activated.

The red MINOR ALARM lamp is on when one of the input references has been lost, or when one of the alarm inputs is activated.

READY A/B

The green lamps indicate that clock input at A and/or B is available and that the corresponding alarm input is not activated.

SELECTED A/B

The green lamps indicate that the A or B clock input has been selected.

1.6.6 Operator Controls

RESET: A momentary contact switch that resets latched MAJOR and MINOR alarms

ACO: Alarm Cut Off. A momentary contact switch that removes the remote alarm condition (unlatches the alarm relays).

AUTO/MANUAL: Enables automatic switchover or manual selection of references.

PWR Turns power ON or OFF. Switch must be pulled out to toggle.

M/S The Master/Slave switch allows two Model 8144-RR's with RS-422/485 outputs to be connected in parallel to enhance system reliability.

1.6.7 User-Configurable Options

Various options are configured using internal DIP Switches and headers. These options are:

- Channel A/B RS-422/485 Alarm Input Termination – selects the termination impedance for the alarm inputs.
- Channel A/B Clock Input Termination – selects the termination impedance for the input reference clocks.
- A/B Pulse Detector – sets the maximum period of time an RS-422/485 input signal can be absent before an alarm is asserted.
- Disable Channel B – for installations where only Channel A input is used.
- Major Alarm Indicator/Relay Latch – selects whether a Major Alarm is latched, or reported only while the problem condition exists.
- Minor Alarm Indicator/Relay Latch – selects whether a Minor Alarm is latched, or reported only while the problem condition exists.

1.6.8 Alarm Outputs

Alarm relays allow remote monitoring of operational status. Relay contacts are provided for Major and Minor Alarms.

1.6.8.1 Alarm Classification

Major Alarm: A Major Alarm is asserted when detected faults compromise output function. The outputs are removed during a Major Alarm condition. The latched alarm relay is reset from the front panel ACO Switch. Faults and conditions listed below actuate a Major Alarm.

LOS	Loss of RS-422/485 reference signal on both inputs.
EXTERNAL ALARM INPUT	An External Alarm Input on both alarm inputs.
POWER FAILURE	External power failure, fuse or internal power supply failure.

Minor Alarm: A Minor Alarm is asserted when failures detected do not affect output function. The latched alarm relay is reset from the front panel ACO switch. Faults and conditions listed below actuate a Minor Alarm:

LOS	Loss of RS-422/485 reference signal on one of the inputs.
EXTERNAL ALARM INPUT	An External Alarm Input on one alarm input.

1.6.8.2 Alarm Interface

Alarm Outputs:	Major Alarm, Minor Alarm
Relay Contacts:	NO, NC and common.
Contact Rating:	30 VDC, 2 amps
Connector:	7-position terminal block (supplied)

SECTION 2 INSTALLATION

2.0 INTRODUCTION

2.1 PREPARATION FOR USE

2.2 SWITCH AND HEADER SETTINGS

INSTALLATION

2.0 INTRODUCTION

This section contains installation instructions for the Model 8144-RR Clock Selector/Distribution Amplifier. To ensure proper operation, read this chapter before operating the unit. There are several internal jumpers and switches that may have to be configured for your specific application.

2.1 PREPARATION FOR USE

This section outlines the set-up procedure for the Model 8144-RR. The switches described in this section are located inside the unit. Refer to Figure 2-2, Model 8144-RR Component Location.

2.1.1 AC Line Voltage Selection

The Model 8144-RR is factory set for 115 VAC $\pm 15\%$, 50/60 Hz power line operation. The instrument may also be operated from a 230 VAC $\pm 15\%$, 50/60 Hz power line. For 230 VAC operation, change the voltage selection drum and line fuse as illustrated in Figure 2-1, and as described below:

1. Remove the line cord (if installed) from the line voltage connector.
2. Open the fuse and selector drum cover with a small flat-bladed screwdriver. Insert the screwdriver blade into the cover notch and pry.
3. Pull the voltage selection drum from the power connector assembly. Insert the drum back into the assembly so that the desired line voltage appears through the cover cut-out.
4. Pull the fuse block from the power connector assembly. Replace the fuse with a 1/4 amp, 250V slow-blow fuse for 230 VAC operation.
5. Reinstall the fuse block into the lower fuse compartment. Make certain the arrow on the fuse block is pointing down.
6. Snap the cover door closed.

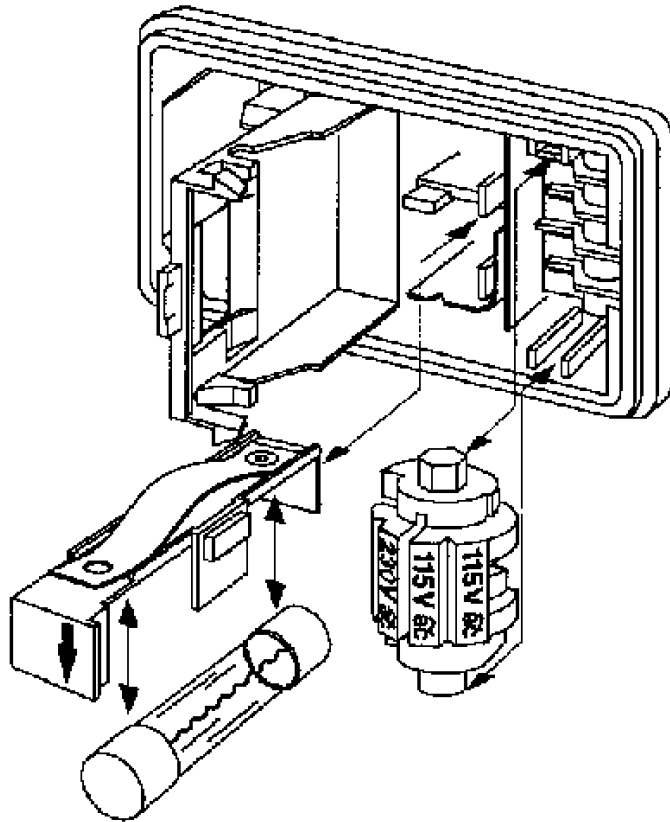

FIGURE 2-1 LINE VOLTAGE SELECTION/FUSE REPLACEMENT

2.1.2 DC Power Options

Check that the power options on the unit match the power available:

Option 52, 12 to 24 VDC:	± 11.0 to 32.0 VDC
Option 54, 48 VDC:	± 55.2 VDC $\pm 20\%$

Check the fuse markings and fuses provided against the values in Section 5.1.

2.2 SWITCH AND HEADER SETTINGS

The switches and headers determine the input alarm and clock termination, reaction to loss of primary (A) and secondary (B) inputs, whether a second clock input is used, and the latching of the alarm lamps and relays.

A summary of the internal settings is below. A more detailed description follows on subsequent pages.

HEADER	FUNCTION	A-B	B-C
H1	B Alarm Termination	120 ohms	High impedance ¹
H2	A Alarm Termination	120 ohms	High impedance ¹
H3	B Clock Termination	120 ohms ¹	High impedance /bridging
H4	A Clock Termination	120 ohms ¹	High impedance /bridging
H5	RS-422/485 B Clock Loss of Input	A = 8 kHz B = 64 kHz	C = 512 kHz D = 1.544 or 2.048 MHz ¹
H6	RS-422/485 A Clock Loss of Input	A = 8 kHz B = 64 kHz	C = 512 kHz D = 1.544 or 2.048 MHz ¹
H7	B Input Alarm Enable	No B Input	B Input ¹
H8	Major Alarm Indicator Latch Select	Latched	Not Latched ¹
H9	Minor Alarm Indicator Latch Select	Latched	Not Latched ¹
H10	Major Alarm Relay Latch Select	Latched	Not Latched ¹
H11	Minor Alarm Relay Latch Select	Latched	Not Latched ¹
H12	Factory Configured		
H13	Factory Configured		
H16	Switching Priority	Non-revertive	Revertive with A Priority ¹
SWITCH	FUNCTION	ON	OFF
S1	Master/Slave	M = Master ¹	S = Slave

¹ =Factory setting

TABLE 2-1 SWITCH AND HEADER SETTINGS SUMMARY

Refer to Figure 2-2, Component Layout, to locate and identify functions of the internal switches and jumpers.

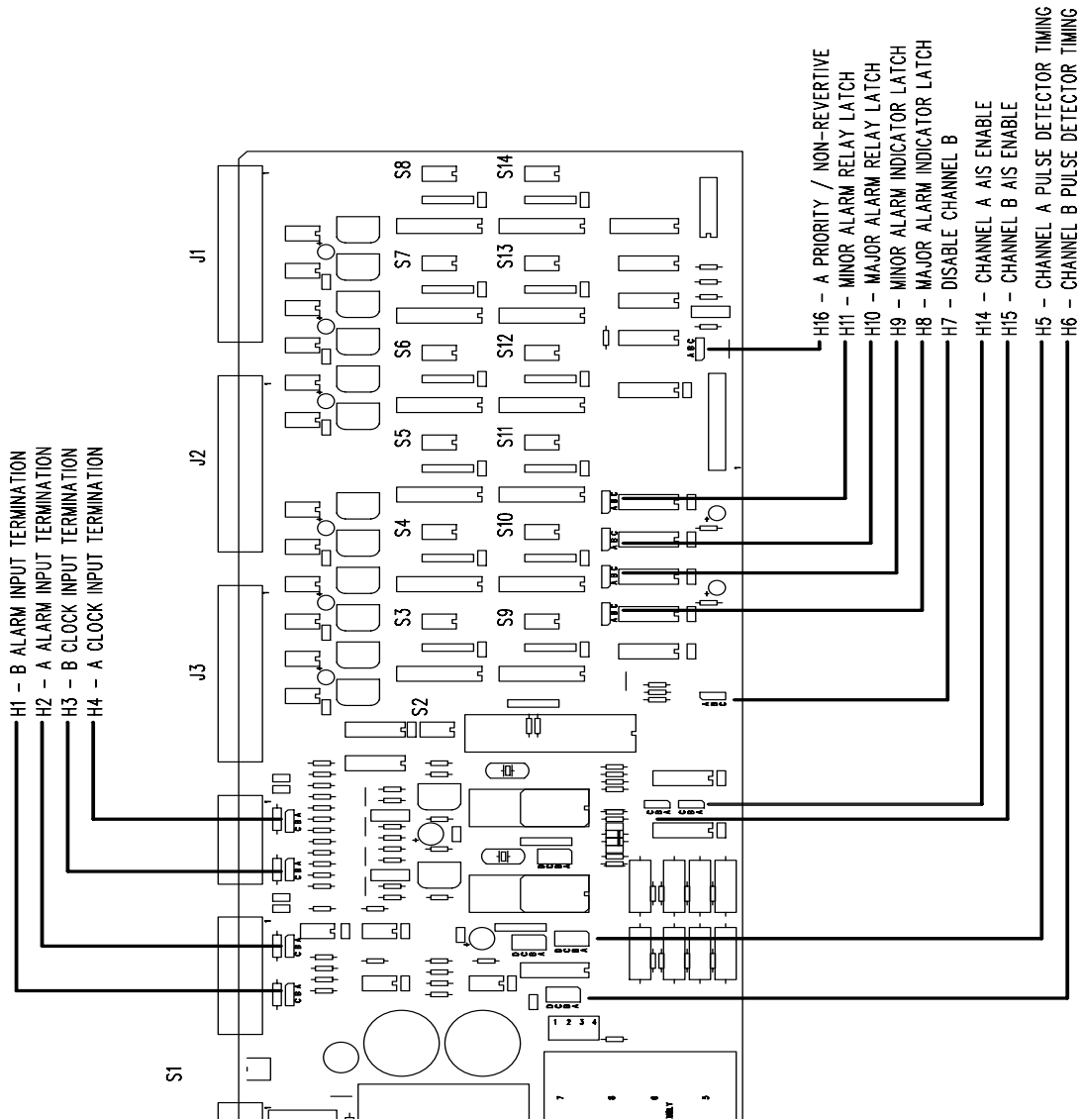

FIGURE 2-2 MODEL 8144-RR COMPONENT LAYOUT

Remove the top cover of the unit to configure the internal jumpers and switches as follows:

Header Position

H1 B Alarm Input Termination

- A-B Terminates the B Alarm RS-422/485 input with 120 ohms between terminals 4 and 5.
- B-C Removes the 120-ohm termination from the B Alarm input. This position may be used as an RS-422/485 input between terminals 4 and 5, or a relay closure between terminals 4 and 6. Use position B-C unless RS-422/485 input line needs termination. If relay closure input is used, the header must be in the B-C position.

H2 A Alarm Input Termination

- A-B Terminates the A Alarm RS-422/485 input with 120 ohms between terminals 1 and 2.
- B-C Removes the 120-ohm termination from the A Alarm input. This position may be used as an RS-422/485 input between terminals 1 and 2 or a relay closure between terminals 1 and 3. Use position B-C unless RS-422/485 input line needs termination. If relay closure input is used, the header must be in the B-C position.

H3 B Clock Termination

- A-B Terminates B Clock input at terminals 4 and 5 with 120 ohms for RS-422/485 inputs.
- B-C Removes the terminating resistor for high-impedance input at terminals 4 and 5 for bridging applications.

H4 A Clock Termination

- A-B Terminates the A Clock input at terminals 1 and 2 with 120 ohms for RS-422/485 inputs.
- B-C Removes the terminating resistor for high-impedance input at terminals 1 and 2 for bridging applications.

Header Position

- H5** This header sets the maximum period of time an RS-422/485 signal can be absent before an alarm is asserted for the B Channel. It is set as follows:
- A Clock Input \geq 4 kHz. Timeout is 310 μ sec typical.
 - B Clock Input \geq 64 kHz. Timeout is 18 μ sec typical.
 - C Clock Input \geq 512 kHz. Timeout is 1.8 μ sec typical.
 - D Clock Input \geq 1.544 and 2.048 MHz. Timeout is 0.68 μ sec typical.

- H6** This header sets the maximum period of time an RS-422/485 signal can be absent before an alarm is asserted for the A Channel. It is set as follows:
- A Clock Input \geq 4 kHz. Timeout is 310 μ sec typical.
 - B Clock Input \geq 64 kHz. Timeout is 18 μ sec typical.
 - C Clock Input \geq 512 kHz. Timeout is 1.8 μ sec typical.
 - D Clock Input \geq 1.544 and 2.048 MHz. Timeout is 0.68 μ sec typical.

H7 B Input Alarm Enable

- A-B If the 8144-RR is used with only an A clock input, connecting A to B on header H7 disables the alarm inputs for the B clock input. Loss of the A reference or the assertion of the A Alarm input now results in a major alarm.
- B-C This is the normal connection using two clock input signals.

A Major Alarm exists when both references are not ready (LOS), or when both external alarm inputs are asserted. A Minor Alarm exists when one of the references is not ready (LOS), or when a single external alarm input is asserted.

Header Position

H8 Major Alarm Indicator Latch Select

- A-B The **MAJOR ALARM INDICATOR** on the front panel is *latched* on by a Major Alarm. A Major Alarm exists when both references are not ready (LOS), or when both external alarm inputs are asserted. The indicator is reset by the RESET switch if either fault is no longer present.
- B-C The **MAJOR ALARM INDICATOR** on the front panel does *not latch*. The indicator is ON only when a Major Alarm is present. The light extinguishes automatically when the condition clears. The RESET switch does not reset the indicator.

Header Position

H9 Minor Alarm Indicator Latch Select

- A-B The **MINOR ALARM INDICATOR** on the front panel is *latched* on by a Minor Alarm. A Minor Alarm exists when one of the references is not ready (LOS), or when a single alarm is asserted. The indicator is reset by the RESET switch if the fault is no longer present.
- B-C The **MINOR ALARM INDICATOR** on the front panel does *not latch*. The indicator is ON only when a Minor Alarm is present. The light extinguishes automatically when the condition clears. The RESET switch does not reset the indicator.

H10 Major Alarm Relay Latch Select

- A-B The **MAJOR ALARM RELAY** is *latched* on by a Major Alarm. A Major Alarm exists when both references are not ready (LOS), or when both external alarms are asserted. The relay is reset by the ACO switch, even though the fault may still be present.
- B-C The **MAJOR ALARM RELAY** does *not latch*. A remote indicator shows only if the fault is present. The ACO switch does not clear the MAJOR ALARM relay.

H11 Minor Alarm Relay Latch Select

- A-B The **MINOR ALARM RELAY** is *latched* on by a Minor Alarm. A Minor Alarm exists when one of the references is not ready (AIS or LOS), or when a single alarm is asserted. The relay is reset by the ACO switch even though the fault may still be present.
- B-C The **MINOR ALARM RELAY** does *not latch*. A remote indicator shows only if the fault is present. The ACO switch does not clear the MINOR ALARM relay.

Header Position

H16 Switching Priority

- A-B Non-revertive switching - in automatic, unit stays on last input selected until an alarm causes a change to the other input.
- B-C Revertive switching with the A input having priority - in automatic, unit selects A input if it is ready.

Switch Position

S1 Master / Slave

- M/S Allows the connection of two units together paralleling the outputs. One unit is set to MASTER, the other to SLAVE. A failure in the master unit puts the output of the master unit into high impedance and enables the slave unit to take over. If only one unit is used, S1 is non-functional.

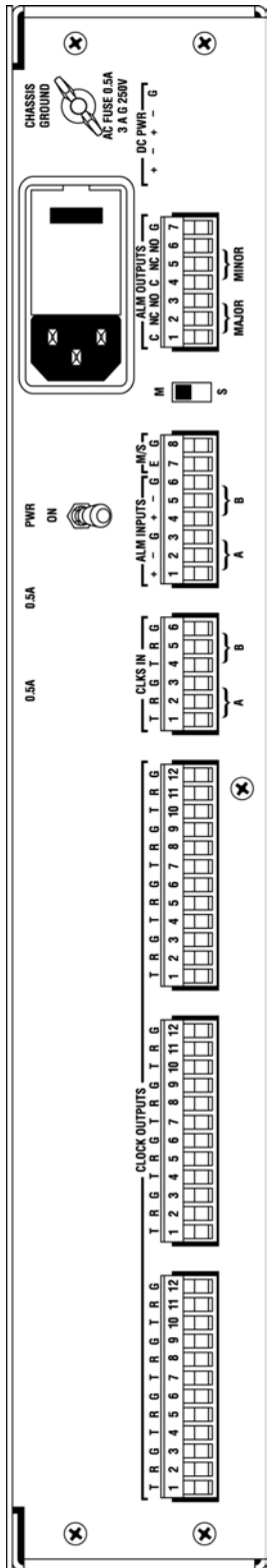

**FIGURE 2-3 8144-RR REAR PANEL
115/230 VAC POWERED UNIT**

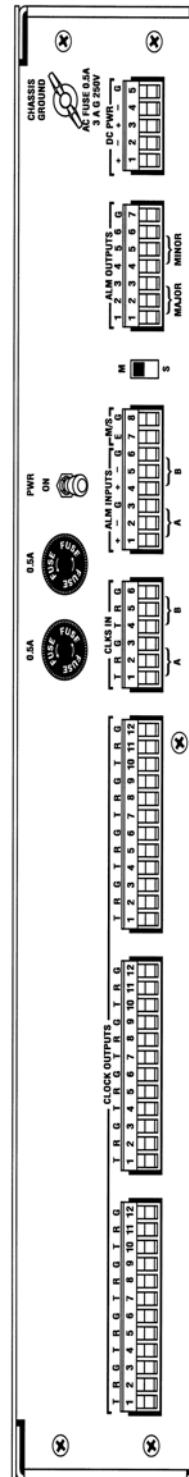

**FIGURE 2-4 8144-RR REAR PANEL
DC POWERED UNIT OPTION 52**

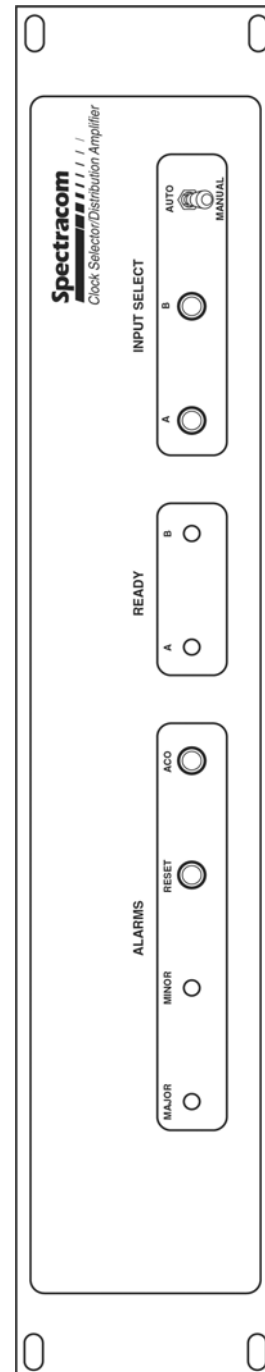
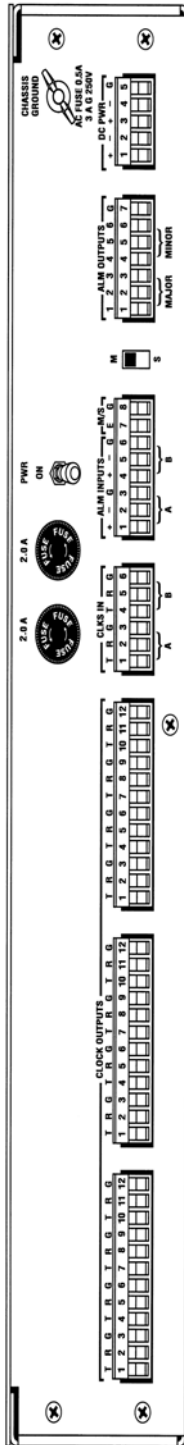

**FIGURE 2-5 8144-RR REAR PANEL
DC POWERED UNIT OPTION 54**

FIGURE 2-6 FRONT PANEL

INSTALLATION CHECKOUT

- 1.0 If applicable, attach one of the optional mounting kits to the unit. Refer to Section 4.4, Mounting Options, for assembly instructions.
- 2.0 Check the unit for physical damage and ensure the **PWR** switch is OFF. Connect a good earth ground to the **CHASSIS GROUND** if desired.
- 3.0 Locate the terminal block connectors in the ancillary kit and install onto rear panel connectors as needed. Refer to Figure 2-3, 8144-RR Rear Panel 115/230VAC Powered Units, for locations. If unit is DC powered, refer to Figures 2-4 and 2-5.
- 4.0 Connect the A clock source to terminals 1 and 2 on the **CLKS IN** terminal block. All wiring to the rear panel terminal blocks can be twisted pair. A ground connection is provided for a shield if desired.
- 5.0 Connect the B clock source to **CLKS IN** terminals 4 and 5.
- 6.0 External alarm sources used to force an input switchover are connected to the **ALM INPUTS** terminal block. The alarm inputs can be either RS-422/485 levels or contact closures.

Pins 1 and 2 are the RS-422/485 A channel alarm inputs. Pins 4 and 5 are the RS-422/485 B channel alarm inputs. In the AUTO mode, a contact closure between 1 and 3 (GND) causes the unit to switch from the A clock source to the B clock source and causes a Minor Alarm. A contact closure between pins 4 and 6 (GND) causes an alarm on the B clock source. **The alarm termination headers H1 and H2 must be in their high impedance (B-C) position to use contact closure for alarm inputs.** An alarm on both inputs will cause a major alarm.
- 7.0 **ALM OUTPUTS** are relay contact closures used for remote indications of clock source failures. During a Major Alarm, Pin 1 on the alarm terminal block is connected to Pin 2 and Pin 3 is open. During a Minor Alarm, Pin 4 on the alarm terminal block is connected to Pin 5 and Pin 6 is open.
- 8.0 Up to twelve loads may be connected to the **CLOCK OUTPUTS**.
- 9.0 Connect the unit to the appropriate power source and switch **PWR** ON.

- 10.0 Check the front panel controls and indicators. Refer to Figure 2-6, 8144-RR Front Panel, for locations of these controls and indicators.
- 10.1 **ALARMS and INDICATORS:**
The **Major** indicator is red if both clock sources have failed. The **Minor** indicator is red if there is a failure of one clock source. Front panel alarm indicators may be cleared with the **RESET** if the clock sources have been restored. The **ACO** clears remote fault indicators even though the alarm conditions still exist.
- 10.2 The **READY** indicators are green if the corresponding clock input is present.
- 10.3 The green **SELECTED** indicator switch corresponds to the input currently selected.
- 10.4 **AUTO/MAN** switch: If revertive A priority has been selected on H16-in the **AUTO** position, a ready A clock source has priority. Failure of the A clock switches the unit to the B clock input. When the A input returns, the unit will switch back to the A input.
- If non-revertive switching has been selected on H16-in the **AUTO** position, selected input can be A or B. Unit stays on the selected input until an alarm causes a switch to the other input. In the **MAN** position, clock selection is operator-controlled.
- 11.0 The Model 8144-RR is now operational.

SECTION 3 OPERATION

3.0 INTRODUCTION

3.1 THEORY OF OPERATION

3.2 FRONT PANEL FUNCTIONS

3.3 REAR PANEL CONNECTIONS

OPERATION

3.0 INTRODUCTION

This section describes the front and rear panel functions, switch functions, and operation information for the Model 8144-RR Clock Selector/Distribution Amplifier.

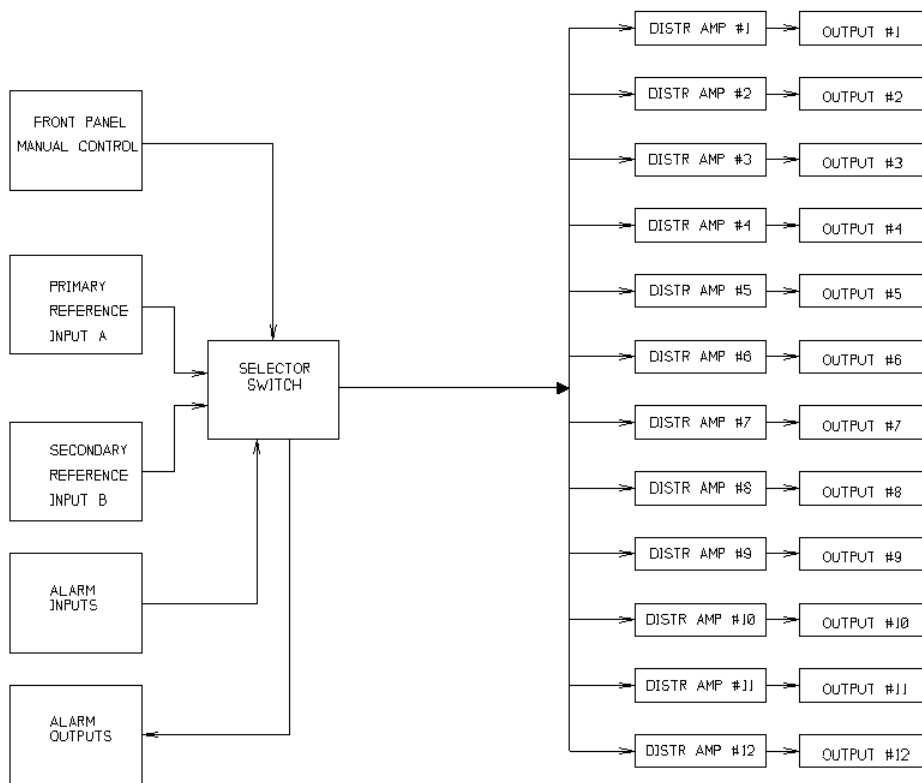

FIGURE 3-1 8144-RR BLOCK DIAGRAM

3.1 *THEORY OF OPERATION*

The Model 8144-RR Clock Selector/Distribution Amplifier is a clock switch and splitter. The input circuit can automatically or manually select a clock input, then send that clock to distribution amplifiers. The distribution amplifiers split the clock to twelve outputs and sends them to the rear panel connectors.

The Model 8144-RR can operate in two modes: Automatic or Manual. In automatic mode, the primary (A) clock has priority and is selected if it is present. If the A clock is not present, the secondary (B) clock is automatically selected. Unit default is “switch and stay” (non-revertive switching), but can be configured to “switch back “ (revertive switching) when the A channel returns. In manual mode, the front panel select pushbuttons determine which channel is selected.

In automatic mode, the channels can be selected remotely by asserting an alarm on the rear panel alarm inputs. Putting an alarm condition on the A channel causes the unit to select channel B. An alarm on channel B causes channel A to be selected.

In manual mode, if a channel is selected and an alarm input is asserted for that channel, the outputs are removed. In either mode, if an alarm is asserted on both rear panel outputs, the outputs are removed.

3.2 *FRONT PANEL FUNCTIONS*

The following paragraphs describe the front panel functions. Refer to Figure 3-2, 8144-RR Front Panel.

MAJOR ALARM Indicator:

A major alarm exists when both clock references are not ready (LOS) or both alarm inputs have been activated. This indicator can be either latched on after the occurrence of an alarm, or on only during the alarm condition. This option is selected by internal header H8. If there is only one reference and internal header H7 is set to A-B, the loss of the A reference or activation of the A alarm causes a major alarm.

A major alarm removes the outputs from the rear panel connectors.

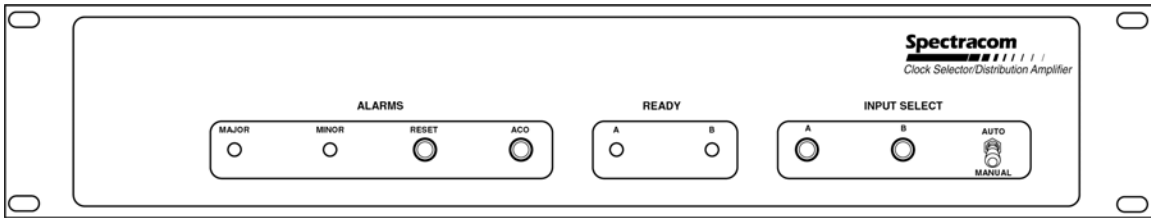

FIGURE 3-2 MODEL 8144-RR FRONT PANEL

MINOR ALARM Indicator:

A minor alarm exists when one of the clock references is lost, or upon the activation of one, but not both, of the alarm inputs.

When only one clock reference is being used, the MINOR ALARM indicator is on constantly, unless header H7 is set to the A-B position.

RESET Pushbutton:

This pushbutton turns off the alarm lamps if the fault causing the alarm has been corrected. If the lamps have been set to non-latching with internal headers H8 and H9, this button has no effect.

ACO Pushbutton:

Alarm Cut Off. This pushbutton unlatches the alarm relays if the fault causing the alarms has been corrected. If the relays have been set to non-latching with the internal headers H10 and H11, this button has no effect.

A READY Indicator:

This lamp is illuminated if the A reference is ready for use and the A alarm is not activated.

B READY Indicator:

This lamp is illuminated if the B reference is ready for use and the B alarm is not activated.

A SELECTED Indicator:

In manual mode, pressing this button selects the A reference. If the A reference is ready, the light remains on to show A is selected.

In automatic mode, if revertive (A priority) has been configured (H16), the lamp is on if the A READY indicator is on. If non-revertive switching has been configured (H16), the lamp will be on only if A is selected.

B SELECTED Indicator

In manual mode, pushing this button selects the B reference. If the B reference is ready, the light remains on to show B is selected.

In automatic mode, if revertive (A priority) has been configured (H16), the lamp is on only if the B READY indicator is lit and the A READY indicator is off. If non-revertive switching has been configured (H16), the lamp will light when B is selected, and remain on until A is selected.

AUTO/MANUAL Switch

This switch selects automatic switchover or manual control of the clock references. In the AUTO position, the unit will automatically switch to the backup channel if it is ready. In the MANUAL position, the SELECTED pushbuttons control which reference is used. With two ready inputs, if either channel is selected and the corresponding input is removed or goes unready, the output is disabled and the MINOR alarm indicator is lit.

3.3 REAR PANEL CONNECTIONS

Figure 3-3, 8144-RR Rear Panel, and the following paragraphs describe the rear panel functions. Each terminal block is a pluggable connector.

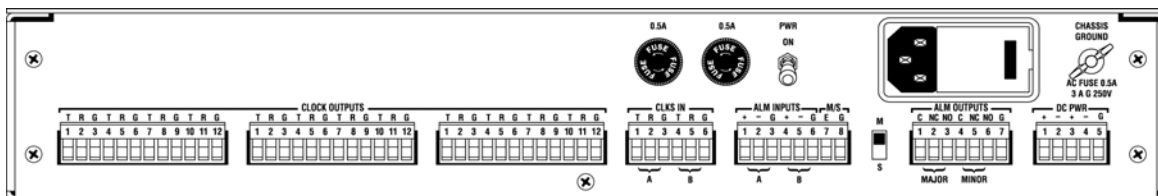

FIGURE 3-3 8144-RR REAR PANEL - AC AND DC CONNECTORS

CLOCK OUTPUTS:

There are three connectors with four clock outputs per connector. Each clock output consists of a Tip, Ring, and Ground triad.

Pin #	Function
1	Tip Output #1, 5, 9
2	Ring Output #1, 5, 9
3	Ground
4	Tip Output #2, 6, 10
5	Ring Output #2, 6, 10
6	Ground
7	Tip Output #3, 7, 11
8	Ring Output #3, 7, 11
9	Ground
10	Tip Output #4, 8, 12
11	Ring Output #4, 8, 12
12	Ground

TABLE 3-1 CLOCK OUTPUT CONNECTOR PINS

CLKS IN:

The reference clocks are connected here. There are Tip, Ring, and Ground triads for each input. The A reference input is connected at pins 1, 2, and 3; the B reference is connected at pins 4, 5, and 6.

ALM INPUTS:

The alarm inputs are connected here. There are two + (plus), - (minus), ground triads for each alarm. The A alarm is on pins 1, 2, and 3, and the B alarm is on pins 4, 5, and 6. The alarm inputs can be either RS-422/485 levels or contact closures. A contact closure between pins 1 and 3 activates the A alarm. A contact closure between pins 4 and 6 activates the B alarm. Making the + (plus) more negative than the - (minus) input activates the alarm.

The alarm termination headers must be in their high-impedance (B-C) position to use contact closures for alarm inputs.

ALM OUTPUTS:

Relay contacts are provided for remote alarm indications. Terminals 1 and 2 provide a contact closure for a MAJOR ALARM (loss of both clock inputs, power failure, etc.), and terminals 1 and 3 provide a contact open. Terminals 4 and 5 provide a contact closure and terminals 4 and 6 provide a contact open for a MINOR ALARM (loss of one reference input). Contacts are rated for 2 amps at 30 VDC and are isolated from ground.

M/S (Master/Slave):

Two 8144-RR's with RS-422/485 outputs may be connected in parallel to enhance system reliability. One unit is designated the MASTER by setting the rear panel slide switch to M. Set the other unit slide switch to S. Use control wires to connect terminal 7 on the MASTER to terminal 7 on the SLAVE, and terminal 8 on the MASTER to terminal 8 on the SLAVE. The master unit inhibits the slave unit until it fails. The slave unit then feeds the loads. The master unit may be disconnected by unplugging the terminal blocks. A spare unit may be installed and designated MASTER before power is turned on.

Power Connections:

Check the serial number tag to verify the power option(s) installed in your 8144-RR.

Standard:	115/230 VAC 50/60 Hz
Option 52,12 to 24 VDC:	±11.0 to 32 VDC
Option 54,48 VDC:	±55.2 VDC ±20%

DC options provide dual fused inputs and reverse polarity protection.

The DC PWR terminals are provided for two DC power sources and polarity is marked on the chassis. **Both sources must have the same polarity referenced to ground.**

If AC power is provided, check the voltage selector in the AC power connector and connect the power cord. If necessary, refer to Section 2.1.1, AC Line Voltage Selection, to change to 230 VAC power.

CHASSIS GROUND:

This ground stud allows connection of the Model 8144-RR chassis to earth ground. Connect the chassis ground to a known well-grounded frame or a ground stake using the largest cable conductor possible.

PWR ON/OFF:

This switch turns power on to the DC to DC converter in the unit.

WARNING: The AC section is always on, if AC power is used.

The red LED inside the unit is illuminated whenever AC power is connected to the unit.

Fuses:

Two DC power fuses are provided if unit is configured for either of the DC power options (Option 52 or Option 54). Fuse markings on rear panel, are listed in Section 5.1.

SECTION 4 OPTIONS

4.1 DC POWER OPTIONS 52 AND 54

4.2 MOUNTING OPTIONS

OPTIONS

4.1 DC POWER OPTIONS 52 AND 54

DC Power Options allow the Model 8144-RR to operate from a DC voltage source. The DC power connection is made at the **DC PWR** terminal block. The optional input voltages are listed below:

OPTION 52	12 to 24 VDC	12 watts (± 11.0 to 32 VDC)
OPTION 54	48 VDC	12 watts (± 55.2 VDC $\pm 20\%$)

The isolated inputs of the DC to DC converter permits either polarity of voltage to be used.

4.2 MOUNTING OPTIONS

There are three mounting options available in addition to the standard 19-inch rack mount.

4.2.1 Option 11, Slides

Option 11 allows the Model 8144-RR to be mounted in a 19-inch rack with slide-out capabilities. Table 4-1 lists the hardware supplied with Option 11. Verify that these items have been received.

Quantity	Description
1	Right-hand slide assembly
1	Left-hand slide assembly
2	Filler plates (not used)
2	Adjustable rear support bracket
1	Hardware Pack containing nut plates, small rear support brackets, and assorted hardware.
1	Hardware pack containing #10 nuts and #10-32 x 1/2 truss head screws
1	Hardware pack containing #10 nuts and #10-32 x 3/8 pan head screws

TABLE 4-1 OPTION 11 CHECKLIST

Install Option 11 as described below:

1. Remove the chassis section from the right-hand slide rail assembly. The right hand assembly is designated with the letters *RH* after the manufacturer's date code label.

Attach the chassis section to the Model 8144-RR using #10-32 screws. The locking tab must be toward the rear of the unit.

2. Repeat Step 1 for the left chassis section.
3. Mount the right and left stationary sections into the rack using the appropriate rear support brackets, nut plates and required hardware.
4. Insert the unit into the rack assembly. Secure the Model 8144-RR to the rack using the front panel mounting holes.

4.2.2 Option 102, 23/24-inch Rack Mount

Option 102 provides the hardware to mount the Model 8144-RR in a 23- or 24-inch rack. Table 4-2 lists the parts supplied with Option 102. Verify that these items have been received.

Quantity	Description
2	23/24 Mounting Plate
4	#10-32 Hex Nut
4	#10 Split Lockwasher
4	#10 Flat Washer
4	#10-32 x 1/2 Philips Pan Head Screw

TABLE 4-2 OPTION 102 CHECKLIST

A Philips screwdriver and a 3/8-inch nut driver are needed to assemble the rack mount kit. To assemble the kit, attach the mounting plates to each side of the Model 8144-RR with the hardware provided.

4.2.3 Option 103, Setback Mount

Option 103 provides the necessary hardware to mount the Model 8144-RR in a setback position. Table 4-3 list the parts supplied with Option 103. Verify that these items have been received.

Quantity	Description
2	Setback Mounting Bracket
4	#10 Split Lockwasher
4	#10-32 x 1/2 Philips Pan Head Screw

TABLE 4-3 OPTION 103 CHECKLIST

A Philips screwdriver is needed to assemble the setback mounting kit. To assemble the kit attach the mounting brackets to each side of the Model 8144-RR with the hardware provided.

SECTION 5 SERVICE INFORMATION

5.0 MAINTENANCE AND CALIBRATION

5.1 FUSE REQUIREMENTS

SERVICE INFORMATION

5.0 MAINTENANCE AND CALIBRATION

There are no components that require periodic maintenance or adjustments.

5.1 FUSE REQUIREMENTS

115 VAC, 0.5 Amp, 250V, Fast-Blo.

230 VAC, 0.25 Amp, 250V, Fast-Blo.

DC options have different fuse requirements.

Option 52, 12 to 24 VDC input: 2.0 Amp, 250V, Slo-Blo (2 required).

Option 54, 48 VDC input: 0.5 Amp, 250V, Slo-Blo (2 required).